

Contents

1 Introduction.....	5
1.1. General Remarks.....	5
1.2. Contents of this Documentation.....	5
1.3. Additional Products and Documents.....	5
1.3.1. Hardware Products.....	5
1.3.2. Software Products.....	6
1.3.3. Documents.....	6
1.4. Items delivered.....	6
1.5. Installation.....	6
1.6. Safety Recommendations and Warnings.....	7
1.7. Life Cycle Information.....	7
1.7.1. Transportation and Storage.....	7
1.7.2. Assembly and Installation.....	7
1.7.3. Operation.....	7
1.7.4. Maintenance and Repair.....	7
1.7.5. Disposal.....	8
2 Product Description.....	9
2.1. Features.....	9
2.2. Connector Assignments.....	11
2.3. Bus Interface (PC/104).....	12
3 Hardware Description.....	13
3.1. Overview.....	13
3.2. Memory and I/O Resources.....	14
3.2.1. General Memory Layout and Configuration.....	14
3.2.2. General I/O Layout and Configuration.....	14
3.2.3. Board Base Address Configuration.....	14
3.2.4. Interrupt Configuration.....	15
3.2.5. Others.....	15
4 Programming Information.....	16
4.1. Overview.....	16
4.2. Register Model and Bit-Utilization.....	16
4.3. Error Handling.....	16
4.4. STOP-Behaviour.....	16
4.5. Memory and I/O Resources.....	17
4.5.1. General Memory Layout and Configuration.....	17
4.5.2. General I/O Layout and Configuration.....	17
5 Technical Data.....	21
5.1. Electrical Data.....	21

5.2.Mechanical Data.....	23
6Firmware.....	24
7Product Revision History.....	25
7.1.Hardware.....	25
7.2.Firmware.....	25
8Manufacturer Information.....	26
8.1.Contact.....	26
8.2.Warranty.....	26

List of Tables

Tab. 1 Process Interface Connector P1.....	11
Tab. 2 PC/104 Bus Connectors PA/PB, PC/PD.....	12
Tab. 3 I/O Address Space Layout.....	14
Tab. 4 I/O Base Address Configuration Switch S1.....	14
Tab. 5 Interrupt Selection Header J1 (2x5 pin).....	15
Tab. 6 I/O Configuration Options Switch S1.....	15
Tab. 7 Factory Programming Header J2 (1x4 pin).....	15
Tab. 8 I/O Address Space Layout.....	17
Tab. 9 Utilization of the individual Bit (READ-Registers).....	18
Tab. 10 Utilization of the individual Bit (WRITE-Registers).....	19
Tab. 11 Interface Specifications and Programming for Inputs.....	20
Tab. 12 Interface Specifications and Programming for Outputs.....	20
Tab. 13 Absolute Maximum Ratings.....	21
Tab. 14 Recommended Operating Conditions.....	22
Tab. 15 Electrical Characteristics.....	22

Tab. 16 Switching Characteristics..... 23

Tab. 17 Hardware Revision State..... 25

List of Figures

Fig. 1 Block Diagram..... 9

Fig. 2 Equivalent Input Circuit..... 10

Fig. 3 Equivalent Output Circuit..... 10

Fig. 4 Process Interface Connector Outline (Front View)..... 11

Fig. 5 Board Layout..... 13

Fig. 6 Mechanical Outline..... 23

1 Introduction

1.1. General Remarks

The content and presentation of this document has been carefully checked. No responsibility is accepted for any errors or omissions in the documentation.

Note that the documentation for the products is constantly revised and improved. The right to change this documentation at any time without notice is therefore reserved.

Syslogic is grateful for any help referring to errors or for suggestions for improvements.

The following registered trademarks are used:

IBM-PC, PC/AT, PS/2	trademarks of IBM Corporation
STPC	trademark of ST Microelectronics
Microwire	registered trademark of National Semiconductor
SPI	trademark of Motorola
I ² C	trademark of Philips Corporation
SocketModem	trademark of Rockwell Semiconductor
FBCube, EUROLOG,	trademarks of Syslogic Datentechnik AG

1.2. Contents of this Documentation

This document addresses to system integrators, programmers and instructed installation and maintenance personal working with the IPC system. It provides all information needed to configure, setup and program the digital input/output board IPC/DIO32-2A and IPC/DIO32-2AE. The boards IPC/DIO32-2A and IPC/DIO32-2AE are functionally identical. They only differ in the operating temperature range (see chapter 5). For complete information also the documentation of the mounted CPU board and communications and I/O boards must be consulted. As the IPC/DIO32 board may be delivered in various versions with optional hardware blocks the standard version (IPC/DIO32-2A) is described here, which includes all hardware function blocks.

1.3. Additional Products and Documents

1.3.1. Hardware Products

The following hardware products are useful together with the IPC/DIO32 board:

- IPC startup guide and tools
- IPC/NETIPC CPU boards
- IPC communication boards
- IPC I/O boards
- (see product catalog for details)

1.3.2. Software Products

The following software products are useful together with the IPC/DIO32 board:

- Firmware for IPC CPU boards: e.g. IPC/NETIPCFW-1A
- Sample program code and utilities for x86 based FBCube systems:
IPC/IOCOMSW-1A

1.3.3. Documents

The following documents are *required* for correct installation and operation of the IPC/DIO32 board:

- DOC/CUBINST: User Documentation for FBCube Installation
Note : also contains the necessary information related to the “ce”-certification of the products
- User Documentation for Basic Firmware (dependent on CPU board)
- DOC/IPC_IOCOMSW: User Documentation for Programming Examples and Utilities

1.4. Items delivered

The IPC/DIO32 module is delivered without any mechanical mounting material. The user should order the required mechanical mounting material according to his needs (open frame mounting, 19"-rack mounting, DIN-rail mounting etc.). Note that the technical documentation is not part of the delivery and must be ordered separately or downloaded from the Internet.

A CPU board, power supply board and enclosure are necessary to build a complete system. All items must be ordered separately and installed according to the respective user documentations.

A standard base configuration could be as follows:

- IPC system with NETIPC-2A CPU board and free slot for I/O board:
IPC/COMPACT2-xx
- external power adapter
- CompactFlash

Note : Mounting procedure is described in DOC/COMPACT2-xx

1.5. Installation

The installation of the IPC system is described in the documentation DOC/CUBINST.

The firmware configuration and download is described in the appropriate firmware documentation.

Important Note

Before applying power to the IPC system the all boards must be correctly configured and mounted (please consult User Documentation of the selected boards).

1.6. Safety Recommendations and Warnings

The products are intended for measurement, control and communications applications in industrial environments. The products must be assembled and installed by specially trained people. The strict observation of the assembly and installation guidelines is mandatory.

The use of the products in systems in which the life or health of persons is directly dependent (e.g. life support systems, patient monitoring systems, etc.) is not allowed.

The use of the products in potentially explosive atmospheres requires additional external protection circuitry which is not provided with the products.

In case of uncertainty or of believed errors in the documentation please immediately contact the manufacturer (address see chapter 8). Do not use or install the products if you are in doubt. In any case of misuse of the products, the user is solely liable for the consequences.

1.7. Life Cycle Information

1.7.1. Transportation and Storage

During transportation and storage the products must be in their original packing. The original packing contains an antistatic bag and shock-absorbing material. It is recommended, to keep the original packing in case of return of the product to the factory for repair. Note that the packing is recyclable.

1.7.2. Assembly and Installation

Observe the EMI-precautions against static discharge. Carefully read the assembly and installation documentation (Document DOC/CUBINST) before unpacking the products. Make sure that you have all the necessary items ready (including all the small parts). Follow the assembly guidelines in DOC/CUBINST strictly.

The installation procedures (contained in document DOC/CUBINST) must be strictly observed. Note that deviations from the installation guidelines may result in degraded operational reliability or in unfavourable EM-radiation or EM-susceptibility.

1.7.3. Operation

The operating environment must guarantee the environmental parameters (temperature, power supply, etc.) specified in the technical specification section of the product manuals.

The main functionality of the system is defined by the application programs running on the system. The application programs are not part of the delivery by Syslogic but are defined, developed and tested by the customer or a system-integrator for each specific application. Refer to the respective documentation for more information.

1.7.4. Maintenance and Repair

The product features error- and malfunction-detection circuitry. Diagnostic information gathered is transferred to the applications software where it can be used. In the rare case of a module hardware-failure or malfunction, the complete module should be exchanged. The faulty module must be returned to the factory for repair. Please use whenever possible the original packing for return of the product (EMI and mechanical protection).

1.7.5. Disposal

At the end of the lifespan the product must be properly disposed. IPC products contain a multitude of elements and must be disposed like computer parts. Some of the IPC products contain batteries which should be properly disposed.

2 Product Description

2.1. Features

The 32-Bit isolated digital input/output board IPC/DIO32-2A, -2AE is used for the input and for the output of digital 24 VDC process signals. The boards IPC/DIO32-2A and IPC/DIO32-2AE are functionally identical, they only differ in the operating temperature range (see technical data section).

The block diagram of the board is shown in Fig. 1.

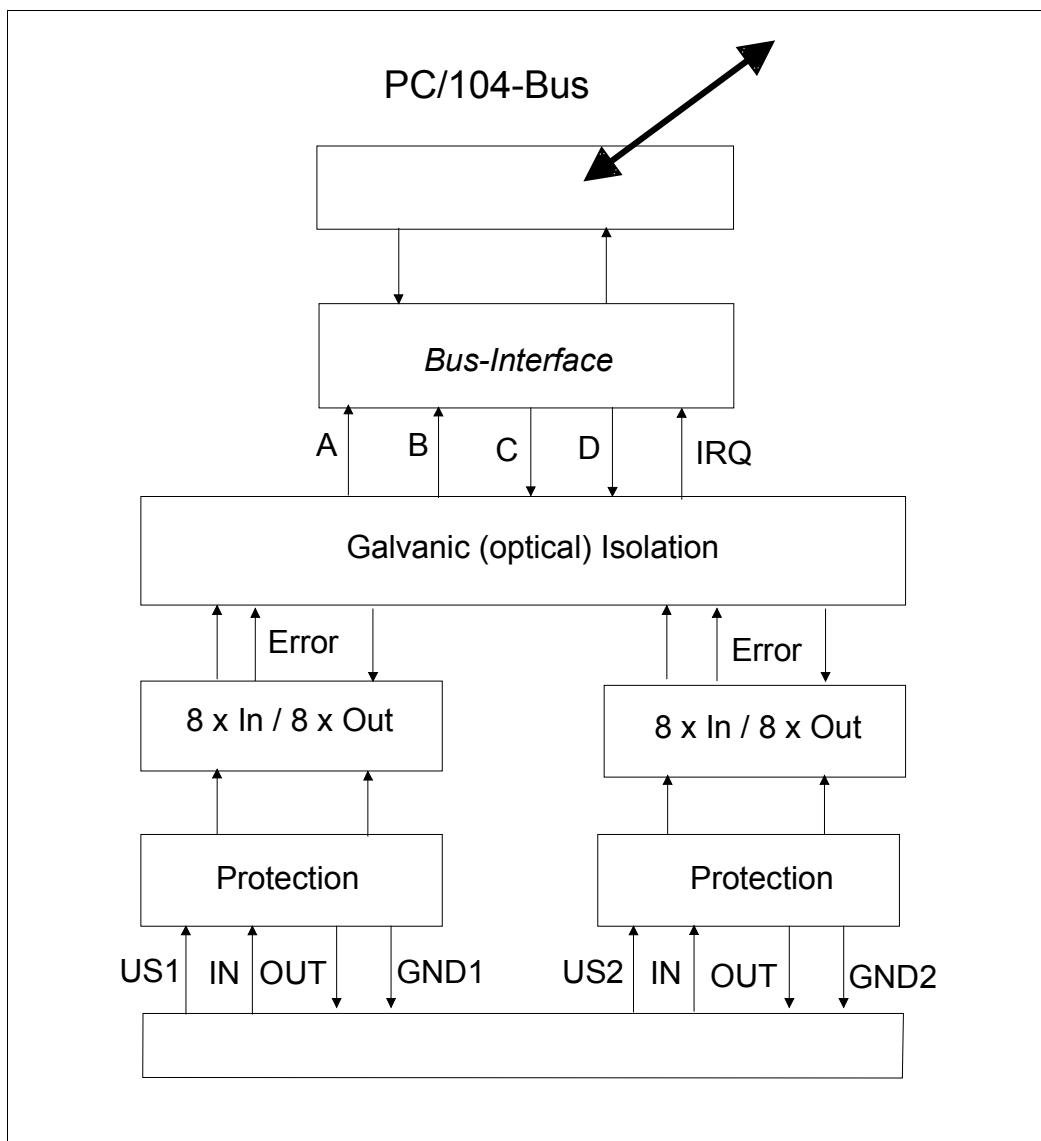

Fig. 1 Block Diagram

The main functional elements are:

- PC/104 local bus interface
- board base address selection switch
- interrupt selection jumper
- 16 bit isolated digital current sinking inputs
- 16 bit isolated digital current sourcing outputs

The outputs are overload protected (thermal). Any overloading of an output will cause an automatic shut-off to protect the output driver circuit on the board. The output driver will automatically switch on again, as soon as the cause of the overload disappears. The error (switch-off) is latched in the error-register and can be read and acknowledged by the software. Missing or low process voltage is also latched in the error bit for output groups only). The board can be programmed to generate an interrupt in case of an error.

The simplified input circuitry of the board is shown in Fig. 2, that of the output circuitry in Fig. 3. The board layout diagram is shown in Fig. 4. The technical data of the board is listed in chapter 5.

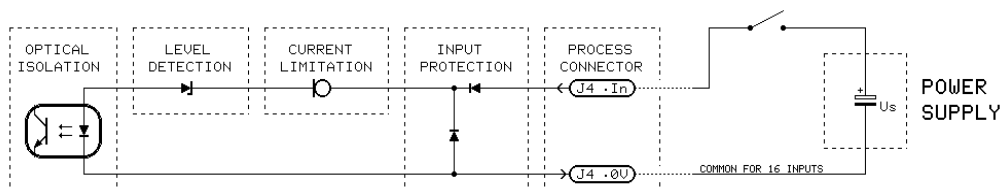

Fig. 2 Equivalent Input Circuit

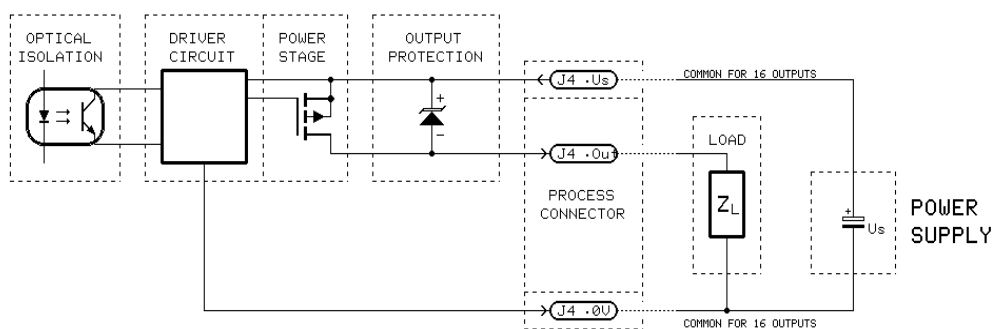

Fig. 3 Equivalent Output Circuit

2.2. Connector Assignments

The input-/output connector/pin assignment for the board is shown in Tab. 1. Please note that input/output groups A and C as well as the input/output groups B and D have a common process signal ground. Sensors (input signals) are connected between process power US and the input pin of the IPC/DIO32 (= current sink inputs). Actuators (output signals) are connected between the output pin of the IPC/DIO32 and ground (= current source outputs).

Mating plug type: Weidmüller B2L 3.5/36F SN SW (Weidmüller ordering code 1748320000)

Field wiring: AWG18...28 / 0.5-1.0 mm²

I/O Connector Pin	Process Interface Signal	I/O Connector Pin	
1	Process Ground A and C (GND1)	2	Process Power A and C (US1)
3	Input A0	4	Output C0
5	Input A1	6	Output C1
7	Input A2	8	Output C2
9	Input A3	10	Output C3
11	Input A4	12	Output C4
13	Input A5	14	Output C5
15	Input A6	16	Output C6
17	Input A7	18	Output C7
19	Process Ground B and D (GND2)	20	Process Power B and D (US2)
21	Input B0	22	Output D0
23	Input B1	24	Output D1
25	Input B2	26	Output D2
27	Input B3	28	Output D3
29	Input B4	30	Output D4
31	Input B5	32	Output D5
33	Input B6	34	Output D6
35	Input B7	36	Output D7

Tab. 1 Process Interface Connector P1

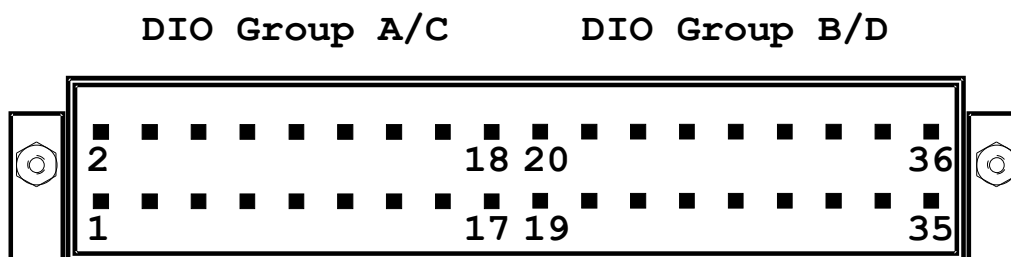

2.3. Bus Interface (PC/104)

The PC/104 bus interface of the IPC/DIO32 allows connection to a wide range of processor boards. The bus interface is described in the IEEE 996 and 996.1 standards documentation. The bus connector pinout is shown in . Depending on the board version the bus connector may have a different form factor but the position of the PC/104 signals stay the same. This enables to support additional bus signals (Vbatt, Power, STOP, etc) on one single connector block.

Pin	Signal Name	Pin	Signal Name	Pin	Signal Name	Pin	Signal Name
				A1	⊗ IOCHCK#	B1	⊗ GND
P11		P12		A2	⊗ SD7	B2	⊗ RESETDRV
1	⊗ GND	1	⊗ GND	A3	⊗ SD6	B3	⊗ +5V
2	⊗ no connection	2	⊗ +5V	A4	⊗ SD5	B4	⊗ IRQ9
3	⊗ no connection	3	⊗ TRIGGER*	A5	⊗ SD4	B5	⊗ -5V (not used)
4	⊗ Vbatt	4	⊗ STOP*	A6	⊗ SD3	B6	⊗ DRQ2
				A7	⊗ SD2	B7	⊗ -12V (not used)
				A8	⊗ SD1	B8	⊗ 0WS#
D0	⊗ GND	C0	⊗ GND	A9	⊗ SD0	B9	⊗ +12V (not used)
D1	⊗ MEMCS16#	C1	⊗ SBHE#	A10	⊗ IOCHRDY	B10	⊗ (KEY)
D2	⊗ IOCS16#	C2	⊗ LA23	A11	⊗ AEN	B11	⊗ SMEMW#
D3	⊗ IRQ10	C3	⊗ LA22	A12	⊗ SA19	B12	⊗ SMEMR#
D4	⊗ IRQ11	C4	⊗ LA21	A13	⊗ SA18	B13	⊗ IOW#
D5	⊗ IRQ12	C5	⊗ LA20	A14	⊗ SA17	B14	⊗ IOR#
D6	⊗ IRQ15	C6	⊗ LA19	A15	⊗ SA16	B15	⊗ DACK3#
D7	⊗ IRQ14	C7	⊗ LA18	A16	⊗ SA15	B16	⊗ DRQ3
D8	⊗ DACK0#	C8	⊗ LA17	A17	⊗ SA14	B17	⊗ DACK1#
D9	⊗ DRQ0	C9	⊗ MEMR#	A18	⊗ SA13	B18	⊗ DRQ1
D10	⊗ DACK5#	C10	⊗ MEMW#	A19	⊗ SA12	B19	⊗ REFRESH#
D11	⊗ DRQ5	C11	⊗ SD8	A20	⊗ SA11	B20	⊗ SYSCLK
D12	⊗ DACK6#	C12	⊗ SD9	A21	⊗ SA10	B21	⊗ IRQ7
D13	⊗ DRQ6	C13	⊗ SD10	A22	⊗ SA9	B22	⊗ IRQ6
D14	⊗ DACK7#	C14	⊗ SD11	A23	⊗ SA8	B23	⊗ IRQ5
D15	⊗ DRQ7	C15	⊗ SD12	A24	⊗ SA7	B24	⊗ IRQ4
D16	⊗ +5V	C16	⊗ SD13	A25	⊗ SA6	B25	⊗ IRQ3
D17	⊗ MASTER#	C17	⊗ SD14	A26	⊗ SA5	B26	⊗ DACK2#
D18	⊗ GND	C18	⊗ SD15	A27	⊗ SA4	B27	⊗ TC
D19	⊗ GND	C19	⊗ (KEY)	A28	⊗ SA3	B28	⊗ BALE
				A29	⊗ SA2	B29	⊗ +5V
				A30	⊗ SA1	B30	⊗ OSC
				A31	⊗ SA0	B31	⊗ GND
				A32	⊗ GND	B32	⊗ GND

Tab. 2 PC/104 Bus Connectors PA/PB, PC/PD

3 Hardware Description

3.1. Overview

The IPC/DIO32-2A, -2AE features 16 digital 24V current sinking inputs and 16 digital 24V current sourcing (high side) outputs. Two groups with 8 inputs and 8 outputs each share the same process power U_s . This two groups are galvanically isolated from each other and from the logic (processor bus) side.

Reading and writing inputs and outputs is done with 8 bit registers in the I/O space of the PC/104 bus.

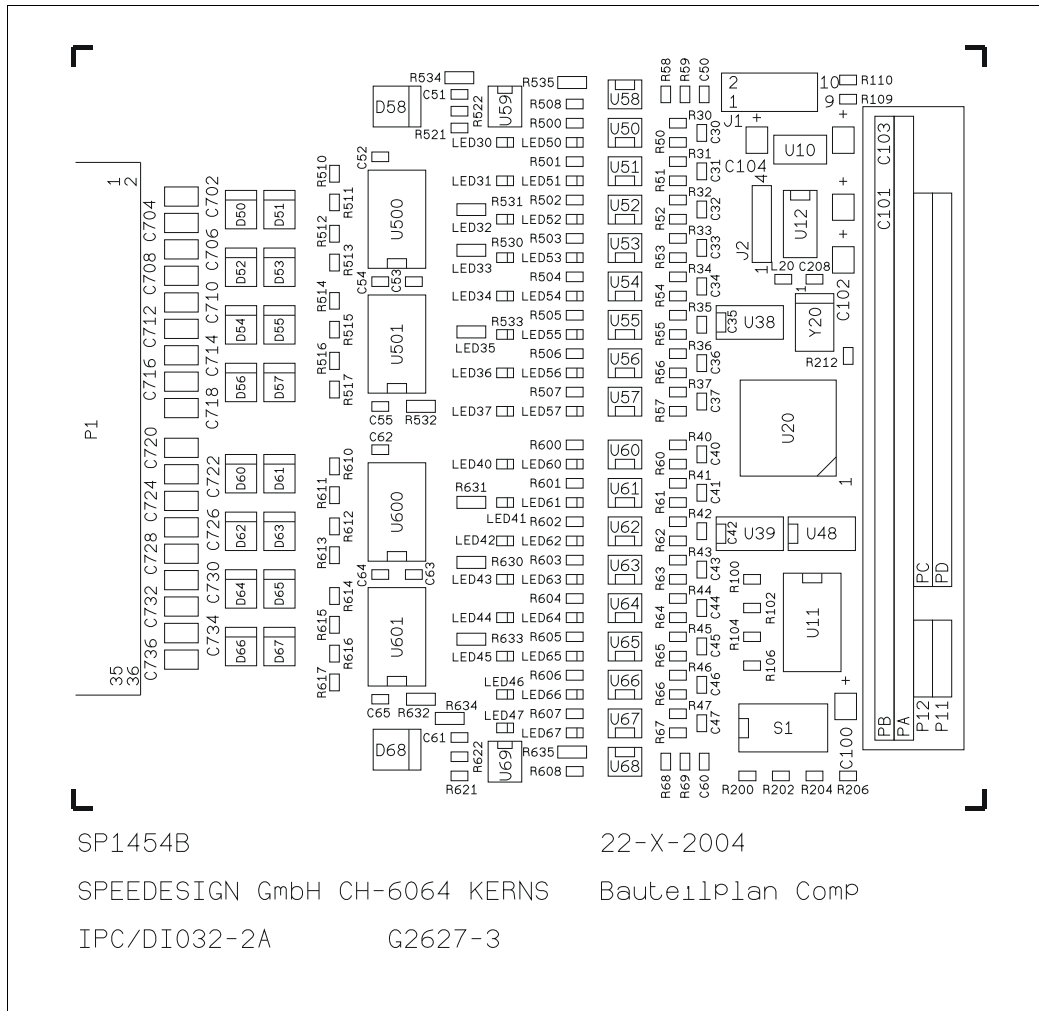

Fig. 5 Board Layout

3.2. Memory and I/O Resources

3.2.1. General Memory Layout and Configuration

The IPC/DIO32 board does not use any memory resources.

3.2.2. General I/O Layout and Configuration

Address	Device / Register	Remarks
Base + 00..03H	Control/Status Registers	
Base + 04..07H	Digital I/O Registers	
Base + 08..1FH	reserved	

Tab. 3 I/O Address Space Layout

3.2.3. Board Base Address Configuration

The base address of the IPC/DIO32 can be selected in the range 0x200..0x3FF and 0x8200..0x83FF according to Tab. 4. The IPC/DIO32 board uses a block of 16 bytes in the I/O space, starting at the configured base address. The base address is defined by setting the sliders of switch S1. Several IPC/DIO32 boards (with different base addresses !) can be used in the same system.

CAUTION: Each board in the IPC system must have its own, unique address range. Overlapping address ranges may damage the boards.

Switch S1 / No address line	6 A15	- A14	- A13	- A12	- A11	- A10	- A9	5 A8	4 A7	3 A6	2 A5	1 A4	A3..0
I/O address													
0x0200	on	0	0	0	0	0	1	on	on	on	on	on	0
0x0210	on	0	0	0	0	0	1	on	on	on	on	off	0
..		0	0	0	0	0	1						0
0x03E0	on	0	0	0	0	0	1	off	off	off	off	on	0
..		0	0	0	0	0	1						0
0x8200	off	0	0	0	0	0	1	on	on	on	on	on	0
0x8210	off	0	0	0	0	0	1	on	on	on	on	off	0
..		0	0	0	0	0	1						0
0x83F0	off	0	0	0	0	0	1	off	off	off	off	off	0

Tab. 4 I/O Base Address Configuration Switch S1

Note: Switch off: 1
 Switch on: 0

3.2.4. Interrupt Configuration

Interrupt selection is done by inserting one jumper on header J1.

Note: Do not insert more than one jumper or put the jumper on a position not defined in Tab. 5. Otherwise the board may get damaged. Interrupt sharing is not supported except for IOCHCK#.

IRQ Selection	Jumper on J1	Remarks
no IRQ	no Jumper	Note: only one Jumper must be inserted on J1 !
IRQ5	Pin 1-2	not shareable
IRQ6	Pin 1-3	not shareable
IRQ7	Pin 4-6	not shareable
IRQ9	Pin 5-6	not shareable
IRQ11	Pin 7-9	not shareable
IRQ15	Pin 6-8	not shareable
IOCHCK#	Pin 9-10	reserved, do not use

Tab. 5 Interrupt Selection Header J1 (2x5 pin)

3.2.5. Others

Switch S1	Configuration	Remarks
7, 8	reserved	do not change

Tab. 6 I/O Configuration Options Switch S1

Pin Number	Signal	Remarks
1	TCK	do not use
2	TDO	do not use
3	TMS	do not use
4	TDI	do not use

Tab. 7 Factory Programming Header J2 (1x4 pin)

4 Programming Information

4.1. Overview

The programming of the DIO32 board is done with standard I/O read and write operations. For detailed information refer to the CPU board's user documentation, firmware documentation and other related documents as listed in paragraph 1.3.

4.2. Register Model and Bit-Utilization

Warning: Do not read from or write into addresses not defined in the register model !

All registers of the IPC/DIO32 are located in the I/O address space. The register model is shown in Tab. 3 and the utilization of the individual bits is listed in Tab. 9 and Tab. 10.

The programming of digital inputs is shown in Tab. 11 and of the digital outputs in Tab. 12.

4.3. Error Handling

The module is thermally overload protected. Any overloading of an output will cause an automatic shut-off and the output driver will automatically switch on again, as soon as the cause of the overload disappears. The error (switch-off condition or missing or low process voltage) is latched in the status-register (RR0/D5) and can be read and acknowledged (dummy write to WR2) by the software. The board can be programmed to generate an interrupt in case of an error (set WR1/D1 = 0). Note that if the error interrupt is enabled, the error condition must be reset by the software ! The output driver switches on automatically (without software intervention) as soon as the overload condition disappears, but the error bit remains set until cleared by the software.

4.4. STOP-Behaviour

The system-wide STOP-line is monitored by the IPC/DIO32 module. As soon as the STOP-line becomes active, the outputs either RESET (= all open, OFF) or FREEZE (i.e.: keep their last state and can not be modified by software). The STOP-behaviour can be programmed (WR1/D2, see and Tab. 10).

4.5. Memory and I/O Resources

4.5.1. General Memory Layout and Configuration

The IPC/DIO32 board does not use any memory resources.

4.5.2. General I/O Layout and Configuration

Register Number	READ Registers	WRITE Registers
00H	Status Register	not used
01H	Control Register	Control Register
02H	Function ID Register	Error Reset Register
03H	not used (FFH)	not used
04H	Digital Inputs A0..A7	not used
05H	Digital Inputs B0..B7	not used
06H	Digital Outputs C0..C7	Digital Outputs C0..C7
07H	Digital Outputs D0..D7	Digital Outputs D0..D7
08-1FH	reserved	reserved

Tab. 8 I/O Address Space Layout

Register	Bit	Meaning	Programming
00H	D0	ATTINT* Attention Interrupt Status	= always 1 (no interrupt)
	D1	ERRINT* Error Interrupt Status	= 0: error interrupt pending = 1: no interrupt pending
	D2	ATTFLAG* Attention Flag	= always 1 (no attention pending)
	D3	ERRFLAG* Error Flag	= 0: error pending (ERROR2*) active = 1: no error pending
	D4	ERROR1* Error Group A/C	= 0: Output error in group C = 1: outputs C0..7 o.k.
	D5	ERROR2* Error Group B/D	= 0: Output error in group D = 1: outputs D0..7 o.k.
	D6	not used	= always 1
	D7	not used	= always 1
01H	D0	ATTEN* ATT Int enable	always 1 (Attention Interrupt disabled)
	D1	ERREN* ERR Int enable	= 0: Error interrupt enabled = 1: Error interrupt disabled Default = 1 (Error interrupt disabled)
	D2	FREEZE STOP mode	= 0: outputs reset on STOP* active = 1: outputs freeze on STOP* active Default = 0 (outputs reset on STOP* active)
	D3..D7	not used	= always 1
02H	D0-D7	FID	= B9H
03H	D0-D7	not used	= FFH
04H	D0-D7	Digital Inputs (A0 .. A7)	D0 = A0, D7 = A7 ()
05H	D0-D7	Digital Inputs (B0 .. B7)	D0 = B0, D7 = B7 ()
06H	D0-D7	Digital Outputs (C0 .. C7)	D0 = C0, D7 = C7 (Tab. 10) 0 = output OFF, 1 = output ON
07H	D0-D7	Digital Outputs (D0 .. D7)	D0 = D0, D7 = D7 (Tab. 10) 0 = output OFF, 1 = output ON
08H-1FH	D0-D7	reserved	

Tab. 9 Utilization of the individual Bit (READ-Registers)

Register	Bit	Meaning	Programming
00H	D0..D7	not used	
01H	D0	ATTEN* ATT Int enable	not used
	D1	ERREN* ERR Int enable	= 0: Error interrupt enabled = 1: Error interrupt disabled Default = 1 (Error interrupt disabled)
	D2	FREEZE STOP mode	= 0: outputs reset on STOP* active = 1: outputs freeze on STOP* active Default = 0 (outputs reset on STOP* active)
	D3..D7	reserved	
02H	D0-D7	ERROR RESET Register	any write resets all error flags in register 1
03H	D0-D7	not used	
04H	D0-D7	not used	
05H	D0-D7	not used	
06H	D0-D7	Digital Outputs (C0 .. C7)	D0 = C0, D7 = C7 (Tab. 10) 0 = output OFF, 1 = output ON
07H	D0-D7	Digital Outputs (D0 .. D7)	D0 = D0, D7 = D7 (Tab. 10) 0 = output OFF, 1 = output ON
08H-1FH	D0-D7	reserved	= do not write

Tab. 10 Utilization of the individual Bit (WRITE-Registers)

Bit in Register	24 VDC input voltage	24 VDC input current
Input „0“ (= inactive)	-10...+10 V	
Input „1“ (= active)	+15...+30 V	max. 5 mA

Tab. 11 Interface Specifications and Programming for Inputs

Bit in Register	output voltage	output current
Output "0" (= inactive)	open	off
Output "1" (= active)	US	on (see Tab. 11 and Tab. 12)

Tab. 12 Interface Specifications and Programming for Outputs

5 Technical Data

5.1 Electrical Data

Important Note

Do not operate the DIO32 board outside of the recommended operating conditions. Otherwise lifetime and performance will degrade.
 Operating the board outside of the absolute maximum ratings may damage the hardware.

Absolute Maximum Ratings (over free-air temperature range)

Parameter	Symbol	Min	Typ	Max	Unit
logic supply voltage	Vcc	-0.5		5.5	Vdc
process input voltage between inputs A0..7 and GND1 resp. B0..7 and GND2	Vin	-0.5		+36	Vdc
process voltage between US1/2 and GND1/2	Us1/2	0		+31	Vdc
isolation: process to chassis (AC, 60s, 500m a.s.l., Ta=25°C)		600			Vrms
process to logic (AC, 60s, 500m a.s.l., Ta=25°C)		2500			Vrms
i/o group A/C to i/o group B/D (AC, 60s, 500m a.s.l., Ta=25°C)		500			Vrms
creepage distance: process to chassis and PCB border		1.0			mm
logic to chassis and PCB border		1.0			mm
process to logic		4.2			mm
i/o group A/C to i/o group B/D		1.0			mm
storage temperature range	Tst	-40		90	°C

Tab. 13 Absolute Maximum Ratings

Recommended Operating Conditions

parameter	Symbol	min	nom	max	Unit
logic supply voltage	Vcc	4.75	5.00	5.25	V
high-level input voltage at A/B0..7 (=input ON)	Vih	15	24	30	V
low-level input voltage at A/B0..7 (=input OFF)	Vil	-10		10	V
process voltage between US1/2 and GND1/2	Us1/2	19	24	30	V
output current at C/D0..7 (load on all 16 outputs)	Io	0	250	300	mA
output current at C/D0..7 (one single output)	Iomax			1.0	A
total output current group C (Us1 to C0..7)	Iog1			4.8	A
total output current group D (Us2 to D0..7)	Iog2			4.8	A
operating free-air ambient temperature (DIO32-2A)	Ta	0		70	°C
operating free-air ambient temperature (DIO32-2AE)	Ta	-40		+85	°C

Tab. 14 Recommended Operating Conditions

Electrical Characteristics

(over recommended operating range, unless otherwise noted)

parameter	Symbol	min	typ	max	Unit
logic supply current (Vcc=5.0V, all in/outputs off)	Icc			150	mA
(all in/outputs on)				200	mA
input current at A/B0..7 (Vin=Vih)	Iih	2.0		5.0	mA
input current at A/B0..7 (Vin=Vil)	Iil			0.5	mA
process supply current US1/2 to GND1/2 (Us1/2=30V, all outputs on, no load, Ta=25°C)	Ius1/2			50	mA
output on resistance (Us=24V, Io=1A, Ta=25°C)	Rds(on)		0.2		Ω
output off leakage current (Us=30V, Ta=25°C)	Io(off)		40		uA
output overcurrent limiting			6..12		A
over-temperature shutdown (junction temperature)			150		°C
incandescent lamp load (Us=24V)		5			W
output inductive clamping voltage	Vcl		Us-45		V
output single pulse avalanche energy	Eas		400		mJ
process supply Us1/2 transient voltage protection, 1ms exponential (TVS-Diode Vbr=33V)			1500		W

Tab. 15 Electrical Characteristics

Switching Characteristics (nominal conditions)

parameter	Symbol	min	typ	max	Unit
input frequency ($V_{in}=\text{nom.}$, duty ratio 1:1)	fimax	2			kHz
input pulse width ($V_{in}=\text{nom.}$)	tw	250			us
input pulse suppression ($V_{in}=\text{nom.}$, duty ratio 1:20)		10			us
input on delay ($V_{in}=\text{nom.}$)	ton		100		us
input off delay ($V_{in}=\text{nom.}$)	toff		180		us
switching frequency ($U_s=24V$, resistive load 250mA)	fomax	1			kHz
switch on delay ($U_s=24V$, resistive load 250mA)	ton			300	us
switch off delay ($U_s=24V$, resistive load 250mA)	toff			400	us

Tab. 16 Switching Characteristics

5.2. Mechanical Data

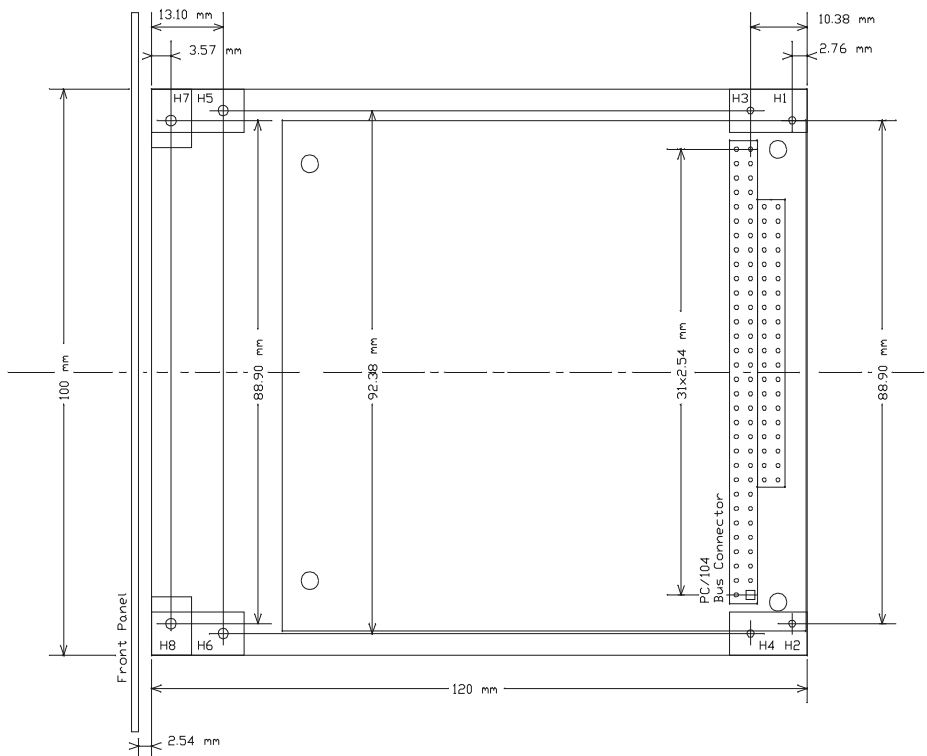

6 Firmware

The DIO32 board does not contain any firmware.

7 Product Revision History

7.1. Hardware

This paragraph lists the different hardware revisions of the DIO32 boards delivered beginning with the first production lot. Note that prototyping boards are not included and must be returned to factory for upgrade or replacement. All information listed in this document relies on definitive state hardware. Therefore this information may be incompatible with the prototyping board hardware.

Important Note

This document always covers the newest product revision listed in Tab. 17.
Please contact the manufacturers technical support for upgrade options.

Board Identification (see product label)	Product Revision	Revision ID Register	Remarks
IPC/DIO32-2A #1	#1	01H	Original Release
IPC/DIO32-2A #2	#2	01H	improved surge immunity
IPC/DIO32-2AE #2	#2	01H	improved surge immunity

Tab. 17 Hardware Revision State

7.2. Firmware

The DIO32 board does not contain any firmware.

8 Manufacturer Information

8.1. Contact

Our distributors and system integrators will gladly give you any information about our products and their use. If you want to contact the manufacturer directly, please send a fax or email message containing a short description of your application and your request to the following address or use one of the information or technical support request forms on our internet homepage:

Syslogic Datentechnik AG
Bruggerstrasse 69
CH-5400 Baden / Switzerland

Email: support@syslogic.ch
www: <http://www.syslogic.ch>
Fax: +41 56 200 9040
Tel: +41 56 200 9050

8.2. Warranty

Our products are covered by a world-wide manufacturers warranty. The warranty period starts at the delivery time from our official distributor to the customer. The duration of the warranty period is specified in the respective product catalogs and the offers. All products carry a date code and a job number for identification. The manufacturing data and deliveries are registered in a high level Quality Management System.

The warranty covers material and manufacturing defects. All products must be returned via the official distributor to the factory for repair or replacement. The warranty expires immediately if the products are damaged or operation outside of the specified recommended operating conditions. The warranty also expires if the date code or job number listed on the product is altered or rendered unintelligible. The warranty does not include damage due to errors in firmware or software delivered with the products.