



## Contents

<b>1</b>	<b>Introduction</b>	<b>5</b>
1.1.	General Remarks	5
1.2.	Contents of this Documentation	5
1.3.	Items delivered	5
1.3.1.	IPC/COMPACT6-1E	5
1.3.2.	IPC/COMPACT6-1F	6
1.3.3.	IPC/COMPACT6-1G	6
1.4.	Additional Products and Literature	6
1.4.1.	Hardware	6
1.4.2.	Software	6
1.4.3.	Operating Systems	7
1.4.4.	Documents	8
1.5.	Safety Recommendations and Warnings	8
1.6.	Electro-Static Discharge	9
1.7.	Life Cycle Information	9
1.7.1.	Transportation and Storage	9
1.7.2.	Assembly and Installation	9
1.7.3.	Operation	9
1.7.4.	Maintenance and Repair	9
1.7.5.	Warranty	10
1.7.6.	RoHS	10
1.7.7.	WEEE and Disposal	10
<b>2</b>	<b>System Overview</b>	<b>11</b>
2.1.	IPC/COMPACT6-1E	11
2.2.	IPC/COMPACT6-1F	12
2.3.	IPC/COMPACT6-1G	13
<b>3</b>	<b>System Configuration</b>	<b>14</b>
3.1.	IPC/COMPACT6-1E	14
3.1.1.	CPU Configuration	14
3.1.2.	Serial Interface Configuration	14
3.2.	IPC/COMPACT6-1F	14
3.2.1.	CPU Configuration	14
3.2.2.	CAN Interface Configuration	14
3.3.	IPC/COMPACT6-1G	15
3.3.1.	CPU Configuration	15
3.3.2.	Serial Interface Configuration	15
<b>4</b>	<b>Enclosure, Assembly and Mounting</b>	<b>16</b>
4.1.	COMPACT6-XS Dimensions	16
4.2.	Internal Cabling	16

4.3.	Serviceable Parts	17
4.4.	Final Mounting of the Enclosure	18
<b>5</b>	<b>Installation and Cabling</b>	<b>19</b>
5.1.	Introduction	19
5.2.	Powering the IPC/COMPACT6-XS System	19
5.3.	Cabling the Interfaces	20
5.3.1.	IPC/COMPACT6-1E	20
5.3.2.	IPC/COMPACT6-1F	21
5.3.3.	IPC/COMPACT6-1G	21
5.4.	Grounding	21
5.5.	Cabling of Communication Links	22
<b>6</b>	<b>Technical Data</b>	<b>24</b>
6.1.	Electrical Data	24
6.2.	EMI / EMC Specification	27
6.2.1.	Relevant Standards	27
6.2.2.	Electromagnetic Emission	27
6.2.3.	Immunity	28
6.3.	Environmental Specification	28
6.4.	Mechanical Data	29
<b>7</b>	<b>Hardware</b>	<b>30</b>
7.1.	Firmware	30
<b>8</b>	<b>Manufacturer Information</b>	<b>31</b>
8.1.	Contact	31

## List of Tables

Tab. 1	Additional Documents	8
Tab. 2	Allowable configuration options	14
Tab. 3	Power connector pinout	19
Tab. 4	Weidmüller power connector	19
Tab. 5	IPC/COMPACT6-1E: Interfaces	20
Tab. 6	IPC/COMPACT6-1F: Interfaces	21
Tab. 7	IPC/COMPACT-6-1G: Interfaces	21
Tab. 8	General Absolute Maximum Ratings	25
Tab. 9	General Recommended Operating Conditions	25
Tab. 10	General Electrical Characteristics	25
Tab. 11	General Switching Characteristics	26
Tab. 12	Electromagnetic Emission	27
Tab. 13	Electromagnetic Immunity	28
Tab. 14	Hardware Revision State	30

## List of Figures

Fig. 1	Functional Block Diagram	11
Fig. 2	Functional Block Diagram	12
Fig. 3	Functional Block Diagram	13
Fig. 4	IPC/COMPACT6-XS	16
Fig. 5	Service of battery or Compact Flash card	17
Fig. 6	One possible way of mounting the IPC/COMPACT6-XS onto the DIN-Rail	18
Fig. 7	Front view with connector markings	20
Fig. 8	Additional grounding of the cable shields at the entry point of a cabinet.	22
Fig. 9	Non isolated communication link with common chassis potential	23
Fig. 10	Isolated communication link	23
Fig. 11	Three side view of the IPC/COMPACT6-XS enclosure	29

# 1 Introduction

## 1.1. General Remarks

The content and presentation of this document has been carefully checked. No responsibility is accepted for any errors or omissions in the documentation.

Note that the documentation for the products is constantly revised and improved. The right to change this documentation at any time without notice is therefore reserved.

Syslogic is grateful for any help referring to errors or suggestions for improvements.

This documentation may contain names, company logos and registered trademarks which are the property of their their respective owners:

IBM-PC, PC/AT, PS/2	trademarks of IBM Corporation
CompactFlash	trademark of SanDisk Corporation
PC/104	trademark of PC/104 Consortium
Geode (AMD)	trademark of Advanced Micro Devices
Windows CE	trademark of Microsoft Corporation
Windows XP Embedded	trademark of Microsoft Corporation

## 1.2. Contents of this Documentation

This document addresses to system integrators, programmers and instructed installation and maintenance personal working with systems mentioned in chapter 1.3. In the following chapters the IPC/COMPACT6-XS stands for the COMPACT XS family with the 6<sup>th</sup> generation CPU board (IPC/NETIPC-6AN).

This documentation provides all information about the system, configuration, assembly, cabling, installation, grounding and EMI-issues of the IPC/COMPACT6-XS. It also contains a chapter with the technical specifications.

## 1.3. Items delivered

The COMPACT6-XS family is built of standard boards and components from Syslogic.

### 1.3.1. IPC/COMPACT6-1E

- IPC/COMPACGP-2ESE
- IPC/NETIPC-6AN
- 2 Slot chrome steel enclosure
- 3V Lithium Battery

### **1.3.2. IPC/COMPACT6-1F**

- IPC/COMPACGP-1F
- IPC/NETIPC-6AN
- 2 Slot chrome steel enclosure
- 3V Lithium Battery

### **1.3.3. IPC/COMPACT6-1G**

- IPC/COMPACGP-2GE
- IPC/NETIPC-6AN
- 2 Slot chrome steel enclosure
- 3V Lithium Battery

## **1.4. Additional Products and Literature**

### **1.4.1. Hardware**

The following items, which have to be ordered separately, complement the system:

- CompactFlash
- SRAM or NVRAM
- Battery for replacement

For a complete list and more detailed information on the additional hardware products please contact the manufacturer or your distributor

### **1.4.2. Software**

The following software products are used together with the COMPACT base board:

- IPC/NETIPCFW-6A: Firmware NETIPC CPU boards
- IPC/IOCOMSW-1A: Sample program code and utilities for x86 based systems

### 1.4.3. Operating Systems

Syslogic offers an implementation for the following operating systems (OS):



Debian Linux Distribution  
IPC/DEBIAN-40A



Microsoft Windows CE 5.0  
IPC/WINCE-50A



Microsoft Windows XP Embedded  
IPC/WINXPE-6A

Others on request.

#### 1.4.4. Documents

Additional documents to the hardware and software described above:

Reference	Ordercode	Document	Manufacturer
[1]	DOC/COMPACGP-1FE	Documentation of the base board IPC/COMPACGP-2EE, -3EE IPC/COMPACGP-1FE, -3FE IPC/COMPACGP-1GE, -3GE	Syslogic AG
[2]	DOC/IPC_NETIPC6-E	User documentation of the IPC/NETIPC-6	Syslogic AG
[3]	DOC/NETIPCFW6-E	User documentation of the firmware	Syslogic AG
[4]	DOC/WINXPE-6A	User manual for the XP Embedded BSP	Syslogic AG
[5]	DOC/WINCE-50A	User manual for the Win CE 5.0 BSP	Syslogic AG
[6]	DOC/DEBIAN-40A	User manual for the Debian Linux Distribution	Syslogic AG
[7]	DOC/IPC_IOCOSW-E	User documentation for programming examples and utilities	Syslogic AG

Tab. 1 Additional Documents

#### 1.5. Safety Recommendations and Warnings

The products are intended for measurement, control and communications applications in industrial environments. The use of the products in systems in which the life or health of persons is directly dependent (e.g. life support systems, patient monitoring systems, etc.) is not allowed. The use of the products in potentially explosive atmospheres requires additional external protection circuitry which is not provided with the products.

In case of uncertainty or of believed errors in the documentation please immediately contact the manufacturer (address see chapter 8). Do not use or install the products if you are in doubt. In any case of misuse of the products, the user is solely liable for the consequences.

The products contain electronic components which will be damaged by electrostatic discharges. The recommendations for handling of sensitive electronic equipment must therefore be strictly followed in all phases of the mounting and installation of the products.

The products are “CE”-certified. The “CE”-conformity, i.e. the compliance to the required standards is only guaranteed if the corresponding mounting, installation, and cabling guidelines are strictly observed.

The products are operated with electrical power. Before manipulating the products, they must be disconnected from the power source and from the communication signals.

The products require set-up procedures before they can be operated. Before being used in an actual installation, they must be correctly configured. If the products are not or wrongly configured, they may malfunction in the intended application.

The products must be assembled and installed by specially trained people. The strict observation of the assembly and installation guidelines is mandatory.

## **1.6. Electro-Static Discharge**

Electronic boards are sensitive to Electro-Static Discharge (ESD). Please ensure that the product is handled with care and only in a ESD protected environment. Otherwise a proper operation is not guaranteed.

## **1.7. Life Cycle Information**

### **1.7.1. Transportation and Storage**

During transportation and storage the products must be in their original packing. The original packing contains an antistatic bag and shock-absorbing material. It is recommended, to keep the original packing in case of return of the product to the factory for repair. Note that the packing is recyclable.

### **1.7.2. Assembly and Installation**

Observe the EMI-precautions against static discharge. Carefully read the assembly and installation guidelines in this document before unpacking the products. Make sure that you have all the necessary items ready (including all the small parts).

The installation procedures must be strictly observed. Note that deviations from the installation guidelines may result in degraded operational reliability or in unfavorable EM-radiation or EM-susceptibility.

### **1.7.3. Operation**

The operating environment must guarantee the environmental parameters (temperature, power supply, etc.) specified in the technical specification section of the manuals.

The main functionality of the IPC/COMPACT6-XS is defined by the application programs running on the system. The application programs are not part of the delivery by Syslogic but are defined, developed and tested by the customer or a system-integrator for each specific application. Refer to the respective documentation for more information.

### **1.7.4. Maintenance and Repair**

The IPC/COMPACT6-XS features error- and malfunction-detection circuitry. Diagnostic information gathered is transferred to the applications software where it can be used. In the rare case of a module hardware-failure or malfunction, the complete module should be exchanged.

The faulty module must be returned to the factory for repair. Please use whenever possible the original packing for returning the product (ESD and mechanical protection).

#### **1.7.5. Warranty**

Our products are covered by a world-wide manufacturers warranty. The warranty period starts at the delivery time from our official distributor to the customer. The duration of the warranty period is specified in the respective product catalogs and the offers. All products carry a job number for identification. The manufacturing data and deliveries are registered in a high level Quality Management System.

The warranty covers material and manufacturing defects. All products must be returned via the official distributor to the factory for repair or replacement. The warranty expires immediately if the products are damaged or operation outside of the specified recommended operating conditions. The warranty also expires if the date code or job number listed on the product is altered or rendered unintelligible. The warranty does not include damage due to errors in firmware or software delivered with the products.

#### **1.7.6. RoHS**

The product of the IPC/NETIPC-6 family are designed and produced according to the Restriction of Hazardous Substances (RoHS) Directive (2002/95/EC).

#### **1.7.7. WEEE and Disposal**

At the end of the lifespan the IPC/COMPACT6-XS must be properly disposed. IPC/COMPACT6-XS contains a multitude of elements and must be disposed like computer parts. The system contains a battery which should be properly disposed.

The products of the IPC/NETIPC-6 are not designed ready for operation for the end-user and intended for consumer applications. Therefore the Waste Electrical and Electronic Equipment (WEEE) Directive (2002/96/EC) is not applicable. But users should still dispose the product properly at the end of life.

## 2 System Overview

### 2.1. IPC/COMPACT6-1E

- AMD Geode LX800 @ 0.9W with 500MHz clock
- 128kB L1-Cache
- 128kB L2-Cache
- 256MB DDR400 SDRAM onboard memory (soldered)
- graphic controller: 1920x1440x32bpp @ 85Hz, 1600x1200x32bpp @ 100Hz
- watchdog
- RTC
- Temperature supervisor
- CompactFlash Type-II socket
- DIL-32 Socket for SRAM or NVRAM
- 44pol. IDE connector
- 2xUSB 2.0 interface
- PS/2 interface
- 10/100 Base-T LAN controller (Intel 82551)
- PC/104 bus
- 10 – 30V DC unisolated power supply
- 1.44MB ROM drive
- 2x RS232 interfaces (16550 compatible)

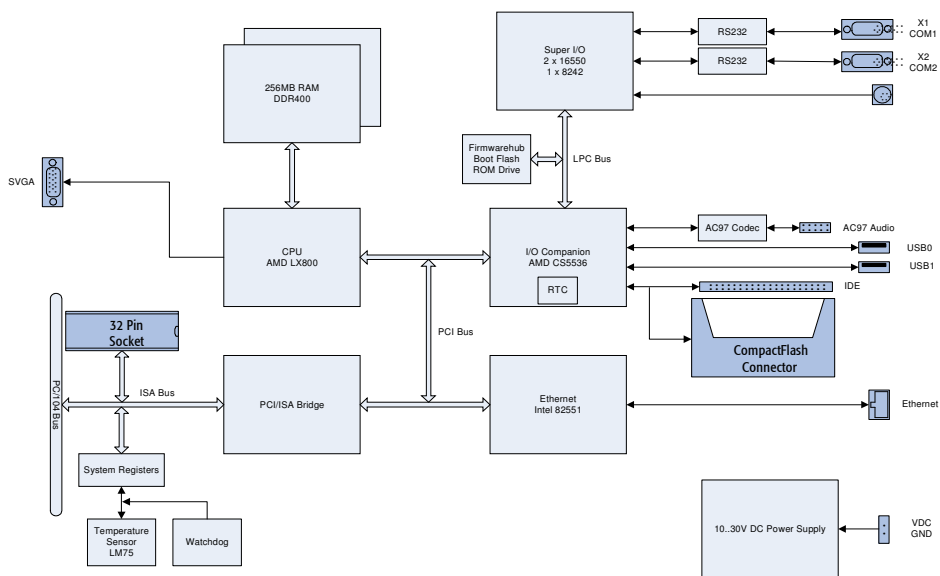

Fig. 1 Functional Block Diagram

## 2.2. IPC/COMPACT6-1F

- AMD Geode LX800 @ 0.9W with 500MHz clock
- 128kB L1-Cache
- 128kB L2-Cache
- 256MB DDR400 SDRAM onboard memory (soldered)
- graphic controller: 1920x1440x32bpp @ 85Hz, 1600x1200x32bpp @ 100Hz
- watchdog
- RTC
- Temperature supervisor
- CompactFlash Type-II socket
- DIL-32 Socket for SRAM or NVRAM
- 44pol. IDE connector
- 2xUSB 2.0 interface
- PS/2 interface
- 10/100 Base-T LAN controller (Intel 82551)
- PC/104 bus
- 10 – 30V DC unisolated power supply
- 1.44MB ROM drive
- 1x RS232 interfaces (16550 compatible)
- CAN 2.0B Controller (SJA1000), isolated interface

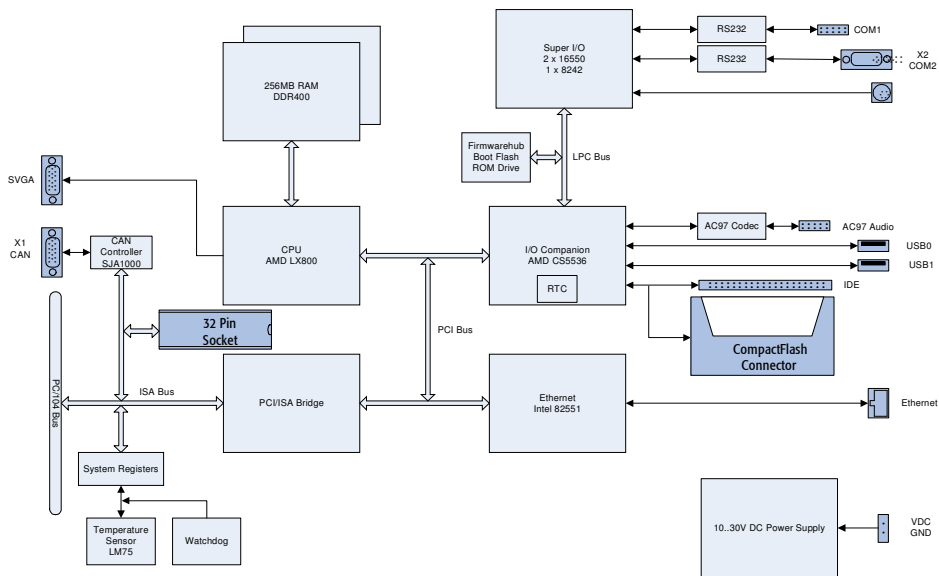

Fig. 2 Functional Block Diagram

### 2.3. IPC/COMPACT6-1G

- AMD Geode LX800 @ 0.9W with 500MHz clock
- 128kB L1-Cache
- 128kB L2-Cache
- 256MB DDR400 SDRAM onboard memory (soldered)
- graphic controller: 1920x1440x32bpp @ 85Hz, 1600x1200x32bpp @ 100Hz
- watchdog
- RTC
- Temperature supervisor
- CompactFlash Type-II socket
- DIL-32 Socket for SRAM or NVRAM
- 44pol. IDE connector
- 2xUSB 2.0 interface
- PS/2 interface
- 10/100 Base-T LAN controller (Intel 82551)
- PC/104 bus
- 10 – 30V DC unisolated power supply
- 1.44MB ROM drive
- 1x RS232 interfaces (16550 compatible)
- 1x RS422/RS485 halb/full duplex, isolated interface

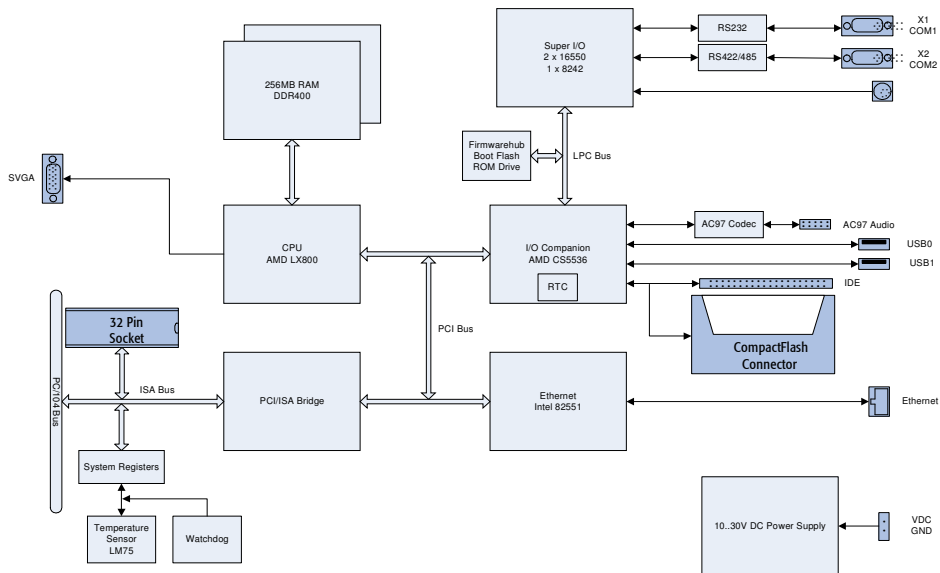

Fig. 3 Functional Block Diagram

## 3 System Configuration

### 3.1. IPC/COMPACT6-1E

#### 3.1.1. CPU Configuration

For detailed information on how to configure the CPU peripherals please consult the documentation of the CPU board [2], chapter 1.4.4.

#### 3.1.2. Serial Interface Configuration

No hardware configuration has to be done.

### 3.2. IPC/COMPACT6-1F

#### 3.2.1. CPU Configuration

For detailed information on how to configure the CPU peripherals please consult the documentation of the CPU board [2], chapter 1.4.4.

#### 3.2.2. CAN Interface Configuration

The CAN interface has to be configured according to the customer's application. Please refer to the IPC/COMPACT6-1F documentation [1], chapter 1.4.4, for a detailed configuration. Please note that not all options described in the aforementioned document can be used. There are some restrictions coming from the CPU/Chipset. The following table gives a list of the options allowed. Otherwise a correct operation cannot be guaranteed.

Description	Allowable Options	Switch/Jumper	Remarks
Addressing Mode	I/O Memory	SW301-8	
Memory Base Address (only if selected)	C0000h ... DBFFFh	SW301-7..0	Restricted
I/O Base Address (only if selected)	7600h	-	Fixed
Active Termination (120E)	On Off	J401	
Interrupt	5 6 11 15	J302	Restricted

Tab. 2 Allowable configuration options

### **3.3. IPC/COMPACT6-1G**

#### **3.3.1. CPU Configuration**

For detailed information on how to configure the CPU peripherals please consult the documentation of the CPU board [2] , chapter 1.4.4.

#### **3.3.2. Serial Interface Configuration**

No hardware configuration has to be done.

## 4 Enclosure, Assembly and Mounting

### 4.1. COMPACT6-XS Dimensions

The enclosure can house a complete industrial control system with many basic functions. The enclosure with its internal electronic system meets EMI/RFI electromagnetic standards according to the European "CE"- requirements (see paragraph 1.5).

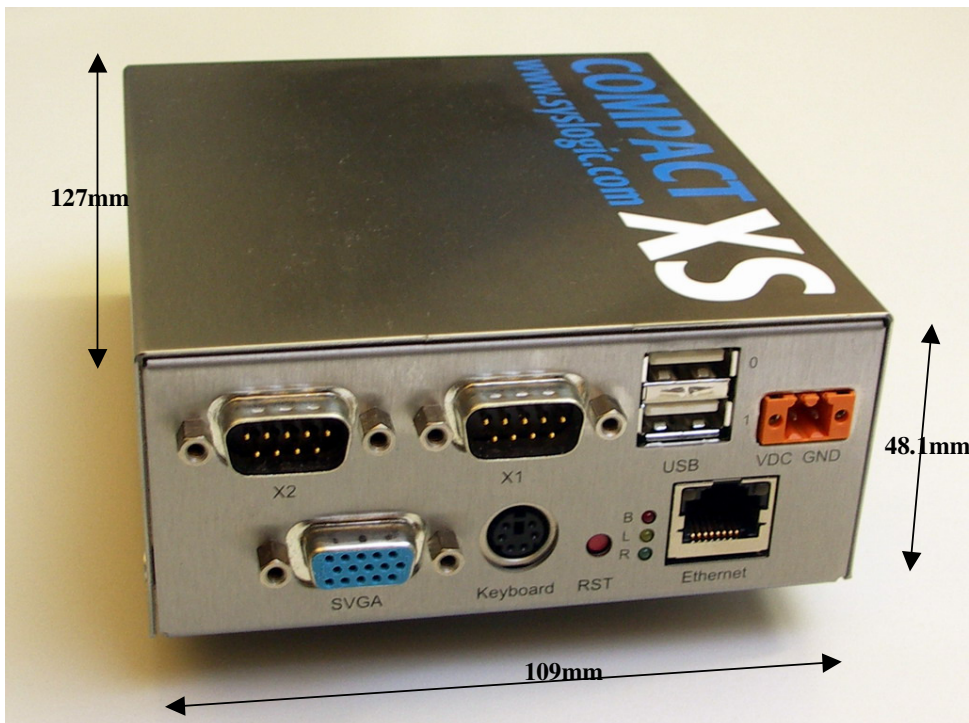

Fig. 4 IPC/COMPACT6-XS

#### Important Notes

Before assembling the whole enclosure with the electronic modules please read through the following paragraphs containing information about the assembling of the system.

### 4.2. Internal Cabling

No internal cabling has to be done.

### 4.3. Serviceable Parts

Two parts inside IPC/COMPACT6-XS may be exchanged from time to time:

- Backup-Battery
- CompactFlash card (has to be ordered separately)

In order to exchange these parts, you must remove the cover by executing steps 1 and 2 of the following instructions.

#### Important Notes

- The battery socket is coded, no wrong insertion of the backup battery is possible.
- Handle the flash memory module with care. A small screwdriver can help to unlock the memory from its socket.

1. Remove 4 screws (M2.5x4, DIN965A, BN3310) on the side of the case.
2. Slide back the cover part of the case.
3. Exchange the battery or the Compact Flash card.

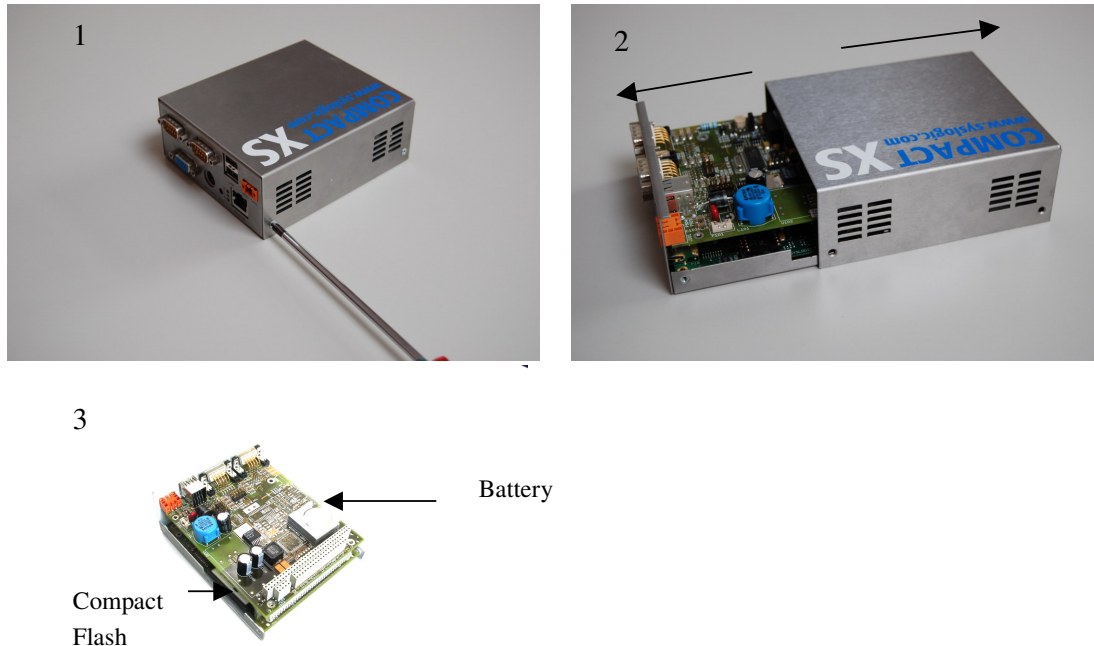

Fig. 5 Service of battery or Compact Flash card

#### Important Notes

When opening the enclosure you're about to handle ESD sensitive devices. Be sure that appropriate precautions have been made to your working environment. from its socket.

#### 4.4. Final Mounting of the Enclosure

There are two possible ways to mount the system onto a DIN-Rail. DIN-Rail clamps can be mounted according to Fig. 6. There are two versions of DIN-Rails available: flat C-Rails (h=7.5mm) and normal C-Rails (h=15mm).

#### Important Notes

Be sure to use the correct screws; screws which are too long can damage the boards inside of the enclosure.

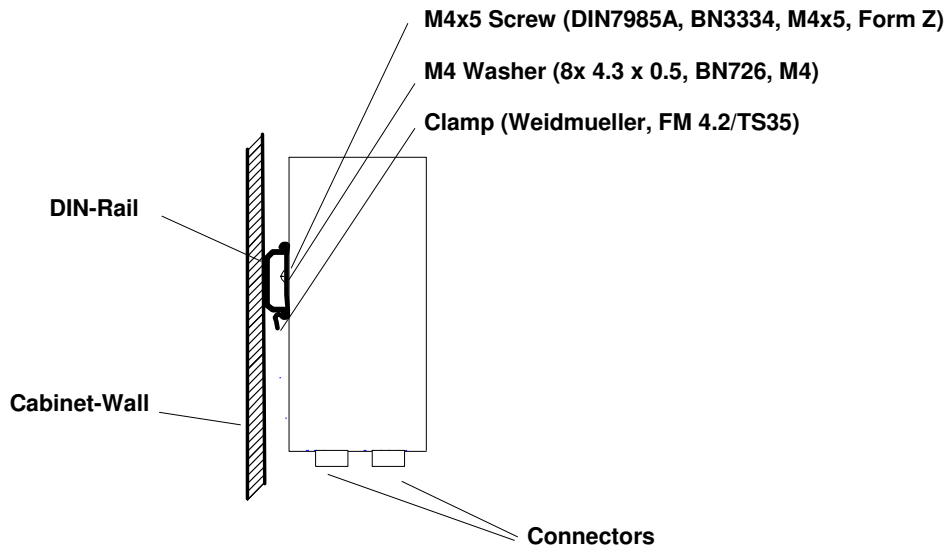

Fig. 6 One possible way of mounting the IPC/COMPACT6-XS onto the DIN-Rail

## 5 Installation and Cabling

### 5.1. Introduction

Installation and cabling of the IPC/COMPACT6-XS system has to be done with great care; the correct cabling is essential for high operational reliability and the correct grounding is necessary for protection. To meet the requirements of "CE"-certification all cables have to be shielded. The enclosure has to be connected to ground via the DIN-rail.

#### Important Notes

To meet the requirements of RFI "CE"-certification, correct mounting, installation and cabling of the IPC/COMPACT6-XS system according to these guidelines is absolutely necessary.

### 5.2. Powering the IPC/COMPACT6-XS System

The "logic voltage", i.e. the power driving the electronic circuits (CPU and base board) is applied from a 24VDC power supply (10VDC...30VDC). The internal power supply converts the input voltage to the logic voltage level. Remember that the power supply is unisolated. For an isolated version please contact the manufacturer. The input voltage is applied with a 2pin Weidmüller connector:

Pin	Description
1	Ground
2	VDC

Tab. 3 Power connector pinout

The connector can be ordered directly at your Weidmüller distributor (order code: *BL3.5/2F*).

Order Code	Type
1606640000	BL3.5/2F

Tab. 4 Weidmüller power connector

When selecting the 24VDC power supply the maximum power dissipation of the system has to be considered.

### Important Notes

Please make sure that the input voltage does not exceed 30V otherwise the base board could get damaged. If the input voltage drops below 10V the system doesn't work properly, correct operation cannot be guaranteed. The best efficiency of the power supply can be achieved if the external input voltage is around 24V. Therefore the power loss of the power supply circuitry is at its minimum. When operating the system at high temperatures please make sure that the power supply is around 24V.

## 5.3. Cabling the Interfaces

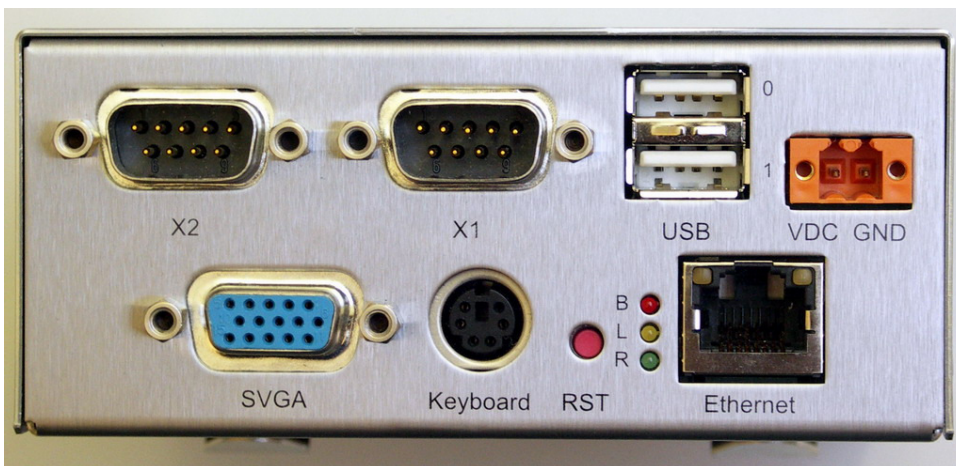

Fig. 7 Front view with connector markings

### 5.3.1. IPC/COMPACT6-1E

Connector Marking	Interface Type
X1	COM1 (RS232)
X2	COM1 (RS232)

Tab. 5 IPC/COMPACT6-1E: Interfaces

### 5.3.2. IPC/COMPACT6-1F

Connector Marking	Interface Type
X1	CAN)
X2	COM2 (RS232)

Tab. 6 IPC/COMPACT6-1F: Interfaces

### 5.3.3. IPC/COMPACT6-1G

Connector Marking	Interface Type
X1	COM1 (RS232)
X2	COM2 (RS422/RS485)

Tab. 7 IPC/COMPACT-6-1G: Interfaces

## 5.4. Grounding

In some cases it is recommended to connect the shields of the cables to chassis potential at the entry point into the housing cabinet as shown in Fig. 8. If the cables enter a hermetically closed cabinet, use special 360 degree metal clamps (RFI protected types which contact to the cable shield).

### Important Notes

Grounding of the cables shields using "pig-tail wires" are not recommended because of their high impedance at high frequencies. It is better to clamp the shields onto a grounded copper rail.

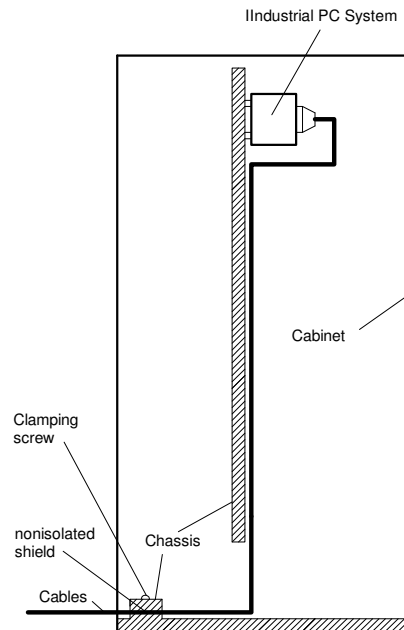

Fig. 8 Additional grounding of the cable shields at the entry point of a cabinet.

### 5.5. Cabling of Communication Links

If the communication ports are unisolated ports, cable shields have to be connected to chassis potential on both sides of the interconnection cable. If the cable is very long, a thick copper wire (10 mm<sup>2</sup>) for potential adjustment is highly recommended. Fig. 9 shows a non isolated system with common chassis ground.

Some of the communication ports are galvanically isolated ports (for more information please refer to the documentation of the base board and the CPU board): in such cases the shield of the interconnection cable must be wired to chassis potential only on one side of the cable. Fig. 10 shows an isolated system with independent grounds.

#### Important Notes

Grounding of cable shields using "pig-tails wires" are not recommended because of their high impedance at high frequencies. It is recommended to clamp the shields onto a grounded copper-rail.

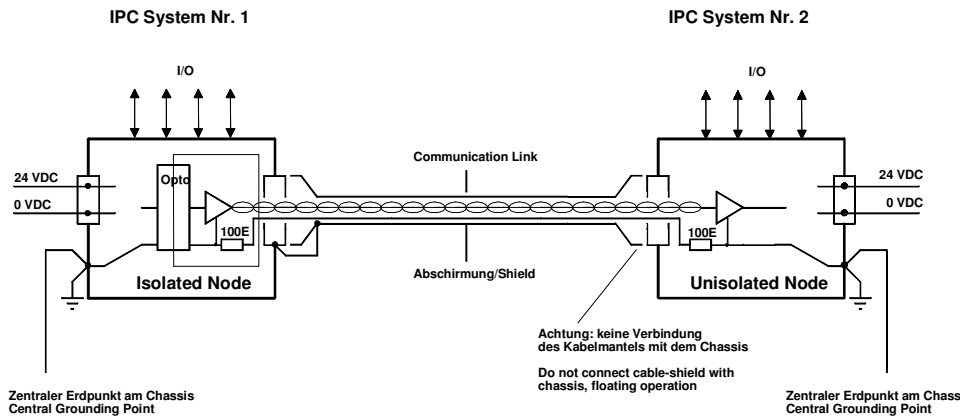

Fig. 9 Non isolated communication link with common chassis potential

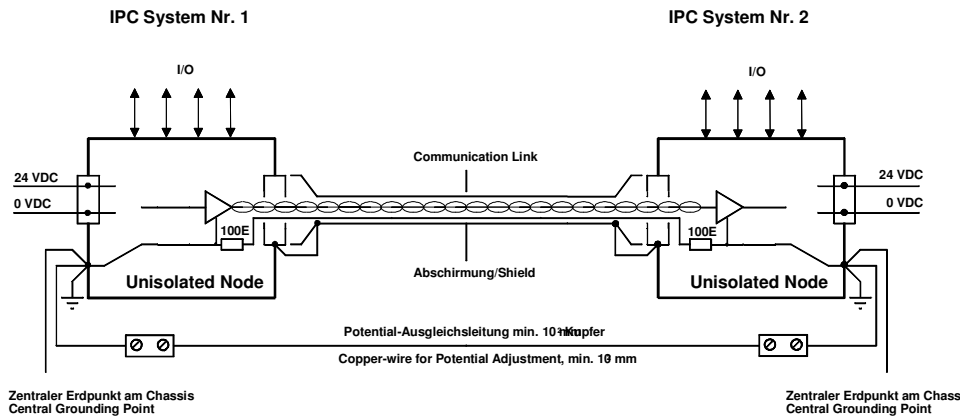

Fig. 10 Isolated communication link

## 6 Technical Data

### 6.1 Electrical Data

#### Important Note

Do not operate the COMPACT6-XS system outside of the recommended operating conditions. Otherwise lifetime and performance will degrade. Operating the board outside of the absolute maximum ratings may damage the hardware.

#### Absolute Maximum Ratings (over free-air temperature range)

Parameter	Symbol	min	nom	max	Unit
<b>IPC/COMPACT6-1F specific ratings</b>					
isolation CAN to chassis (AC, 60s, 500m a.s.l., Ta=25°C)		1000			Vrms
Isolation CAN to logic (AC, 60s, 500m a.s.l., Ta=25°C)		1500			Vrms
creepage distance CAN to logic		1.6			mm
creepage distance CAN to chassis		2.5			mm
<b>IPC/COMPACT6-1G specific ratings</b>					
isolation RS422/RS485 to chassis (AC, 60s, 500m a.s.l., Ta=25°C)		1000			Vrms
Isolation RS422/RS485 to logic (AC, 60s, 500m a.s.l., Ta=25°C)		1000			Vrms
creepage distance RS422/RS485 to logic		2.0			mm
creepage distance RS422/RS485 to chassis		1.0			mm
<b>Non-specific ratings</b>					
internal power supply voltage	Vcc	-0.5		5.5	Vdc
isolation logic to chassis (AC, 60s, 500m a.s.l., Ta=25°C)		500			Vrms
isolation RJ45 to logic (AC, 60s, 500m a.s.l., Ta=25°C)		1500			Vrms
isolation RJ45 to chassis (AC, 60s, 500m a.s.l., Ta=25°C)		1000			Vdc
creepage distances:					
logic to chassis and PCB boarder		1.0			mm
logic to PC/104 mounting holes		0.5			mm

RJ45 to logic		2.5			mm
RJ45 to chassis and PCB boarder		2.0			mm
storage temperature range	Tst	-40		90	°C

Tab. 8 General Absolute Maximum Ratings

### Recommended Operating Conditions

Parameter	Symbol	min	nom	max	
external power supply	Vext	10	24	30	Vdc
battery backup voltage (Io=100µA)	Vbatt	2.70	3.00	3.60	Vdc
PS/2 connector (P3/P4) power load (+5V)	Ips2			200	MA
operating free-air temperature range	Ta	0		55	°C

Tab. 9 General Recommended Operating Conditions

### Electrical Characteristics

(over recommended operating range, unless otherwise noted)

Parameter	Symbol	min	Typ	max	Unit
<b>IPC/COMPACT6-1E specific electrical characteristics</b>					
full load power dissipation @ 24Vdc (no external loads)	Pmax		8.7	11	W
<b>IPC/COMPACT6-1F specific electrical characteristics</b>					
full load power dissipation @ 24Vdc (no external loads)	Pmax		9.8	12	W
<b>IPC/COMPACT6-1G specific electrical characteristics</b>					
full load power dissipation @ 24Vdc (no external loads)	Pmax		8.9	11	W
<b>Non-specific electrical characteristics</b>					
Vbatt loading (Vcc=0V, without SocketMemory)	Ibat(off)		3.5	10.0	µA
Vbatt loading (Vcc=5V)	Ibat(on)		1.5	4.0	µA
LOWBAT* trip point		2.35	2.5	2.65	V
VRT trip point (RTC Valid RAM and Time Flag)			2		V
AC97 Line In			1		Vrms
AC97 Mic In			1		Vrms
AC97 Line Out		0.85	1	1.15	Vrms

Tab. 10 General Electrical Characteristics

**Switching Characteristics**  
**(over recommended operating range, unless otherwise noted)**

Parameter	Symbol	min	nom	max	
<b>IPC/COMPACT6-1E specific switching characteristics</b>					
COM1 baud rate (RS232)				115.2	kBaud
COM2 baud rate (RS232)				115.2	kBaud
<b>IPC/COMPACT6-1F specific switching characteristics</b>					
CAN Bitrate				1	MBit/s
COM2 baud rate (RS232)				115.2	kBaud
<b>IPC/COMPACT6-1G specific switching characteristics</b>					
COM1 baud rate (RS232)				115.2	kBaud
COM2 baud rate (RS422/RS485)				115.2	kBaud
<b>Non-specific switching characteristics</b>					
processor clock (NETIPC-6A, -6AN)	pclk			500	MHz
memory clock (IPC/NETIPC-6A, -6AN)	mclk			200	MHz
Watchdog timeout (short period)	Tw	70	100	140	ms
Watchdog timeout (long period)	Tw	1.0	1.6	2.25	s
Timer base clock 1	fclk1		14.318		MHz
Timer base clock 1 accuracy				+/-100	ppm
Timer base clock 2	fclk2		32.768		kHz
Timer base clock 2 accuracy				+/-20	ppm
Timer base clock 2 aging				+/-3	ppm/year
Real Time Clock base clock	fclk		32.768		kHz
Real Time Clock accuracy (25°C)				+/-20	ppm
Real Time Clock temperature coefficient				-0.04	ppm/(°C) <sup>2</sup>
Real Time Clock aging				+/-3	ppm/year
AC97 Sampling rate				48	kHz
AC97 DAC dynamic range		85			dB
AC97 ADC dynamic range		80			dB

Tab. 11 General Switching Characteristics

## 6.2. EMI / EMC Specification

### 6.2.1. Relevant Standards

The IPC/COMPACT6 has been designed to comply the the following standards are certified according to European Union "CE"-requirements:

- EN 55022 Information technology equipment-  
Radio disturbance characteristics-  
Limits and methods of measurement
- EN 55024 Information technology equipment-  
Immunity characteristics-  
Limits and methods of measurement
- EN61000-2-2 Generic standard - immunity Standard for industrial environments.
- EN61000-2-4 Generic standard - emission standard for industrial environments.
- EN 50121-3-2 Railway applications – Electromagnetic compatibility – Part 3-2: Rolling stock – apparatus
- EN 55011 Industrial scientific and medical (ISM) radio-frequency equipment – Electromagnetic disturbance characteristics – Limits and methods of measurement

### 6.2.2. Electromagnetic Emission

Test	Limit	Performance Criteria	Result	Remarks
Stationary interference voltage on the AC voltage terminals V-Network 0.15 – 30 MHz Power supply line Control and signal lines	EN 55022	Class A	PASS	Compliant with EN 50121-3-2 (referring to EN 55011)
Radiated E-Field, horizontal and vertical polarized E-Field-Aenna 30 – 100 MHz EUT with all cables	EN 55022	Class A	PASS	Compliant with EN 50121-3-2 (referring to EN 55011)

Tab. 12 Electromagnetic Emission



## 6.4. Mechanical Data

The enclosure can house a complete industrial control system with many basic functions. The enclosure with its internal electronic system meets EMI/RFI electromagnetic standards according to the European "CE"- requirements (see paragraph 1.5). The figure below shows the IPC/COMPACT6-XS from its three sides.

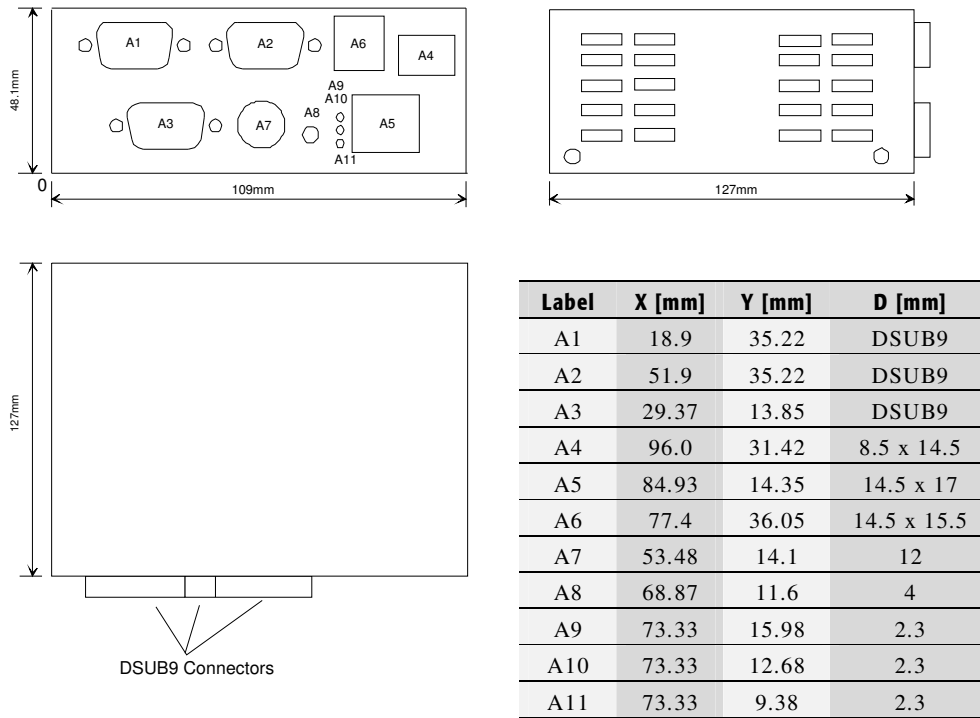

Fig. 11 Three side view of the IPC/COMPACT6-XS enclosure

## 7 Hardware

This paragraph lists the different hardware revisions of the IPC/COMPACT6-XS systems delivered beginning with the first production lot. Note that prototyping boards are not included and must be returned to factory for upgrade or replacement. All information listed in this document relies on definitive state hardware. Therefore this information may be incompatible with the prototyping board hardware.

### Important Note

This document always covers the newest product revision listed in Tab. 14.  
Please contact the manufacturers technical support for upgrade options.

Board Identification (see product label)	Product Revision	Remarks
IPC/COMPACT6-1E #1	1	Original release
IPC/COMPACT6-1F #1	1	Original release
IPC/COMPACT6-1G #1	1	Original release

Tab. 14 Hardware Revision State

### 7.1. Firmware

Please refer to the appropriate firmware documentation [3] of the IPC/NETIPC-6AE for detailed information.

## 8 Manufacturer Information

### 8.1. Contact

Our distributors and system integrators will gladly give you any information about our products and their use. If you want to contact the manufacturer directly, please send a fax or email message containing a short description of your application and your request to the following address or use one of the information or technical support request forms on our internet homepage:

Syslogic Datentechnik AG  
Taefernstrasse 28  
CH-5405 Baden-Daettwil / Switzerland

Email: [info@syslogic.ch](mailto:info@syslogic.ch)  
www: <http://www.syslogic.ch>  
Fax: +41 (0)56 200 90 50

Technical support:  
[support@syslogic.ch](mailto:support@syslogic.ch)